

Saffire LX-I & Saffire EVO LZ-I

2-3/8" Backset 4" door preparation

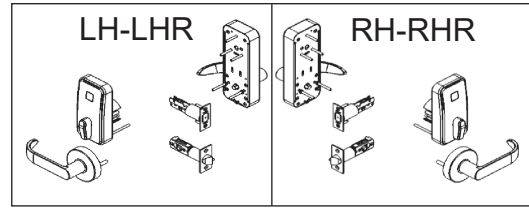

- NOTES:
1. USE DIMENSIONS FROM TABLE BELOW TO ADJUST BACKSET POSITION ACCORDING TO LOW AND HIGH BEVEL DOOR EDGE.
 2. DIMENSIONS ARE SYMETRICAL ABOUT \bar{Q} UNLESS OTHERWISE NOTED.
 3. DO THE CUT OUT ACCORDING TO SELECTED LATCH BOLT (1" OR 1-1/8").
 4. IF THE SELECTED LATCH BOLT HAS RADIUS, MAKE CUT OUT WITH RADIUS.
 5. DRAWING IS NOT TO SCALE.
 6. DIMENSIONS ARE IN INCHES [mm].

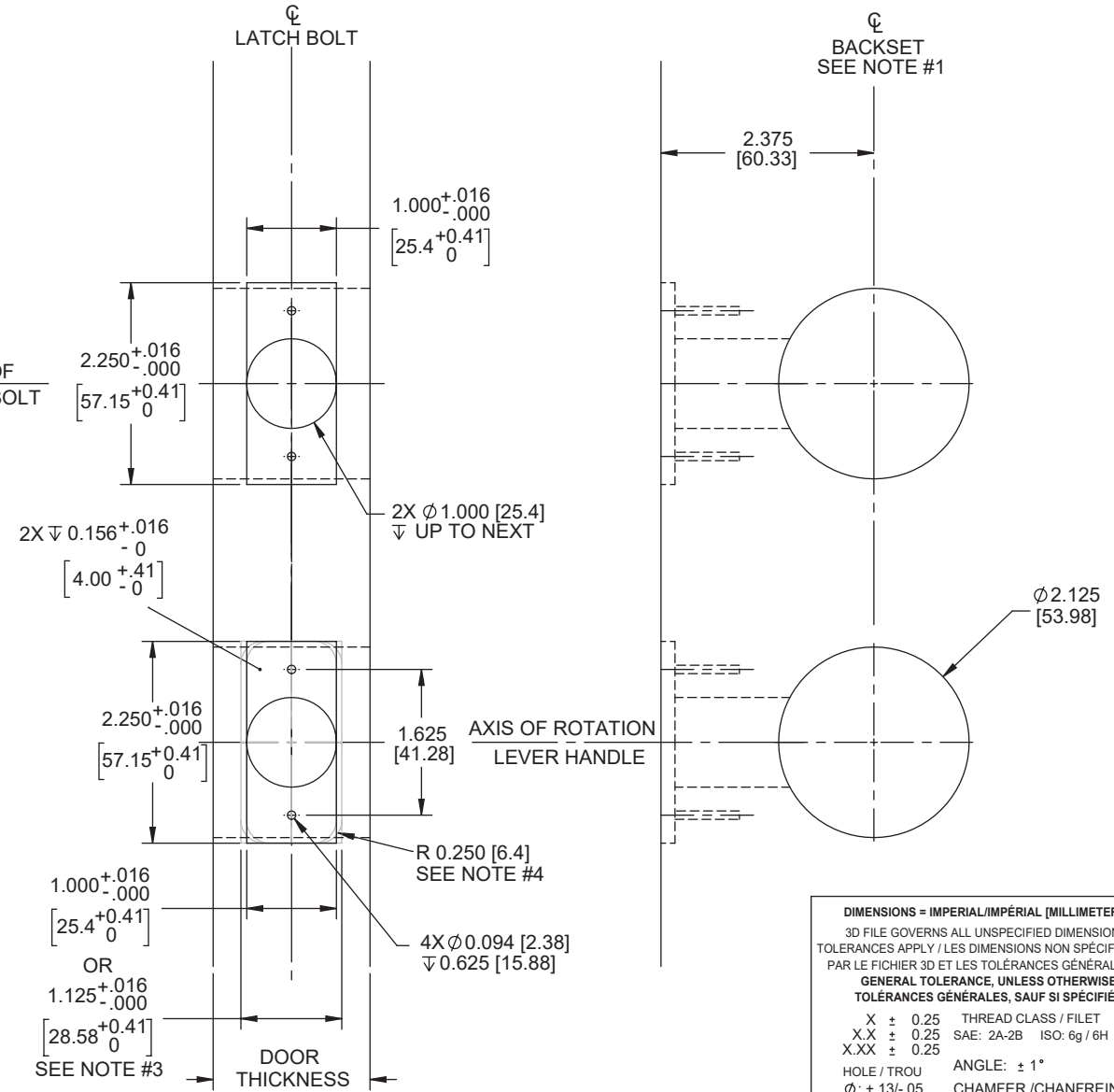
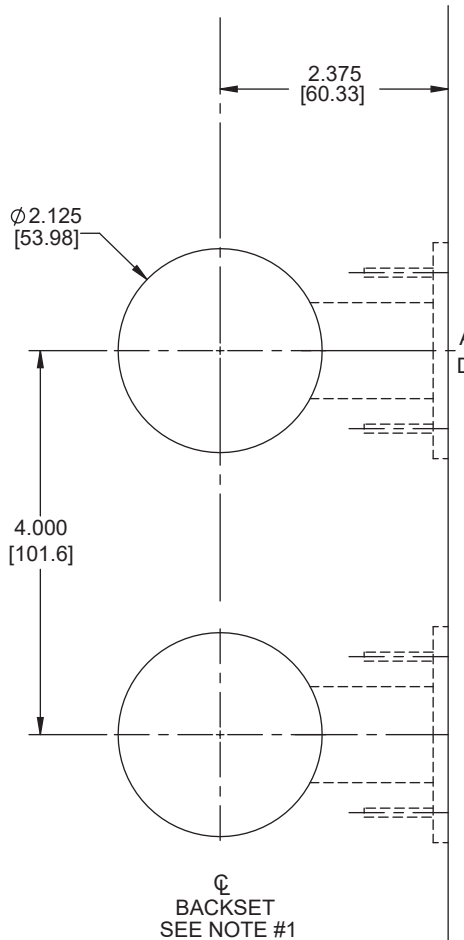
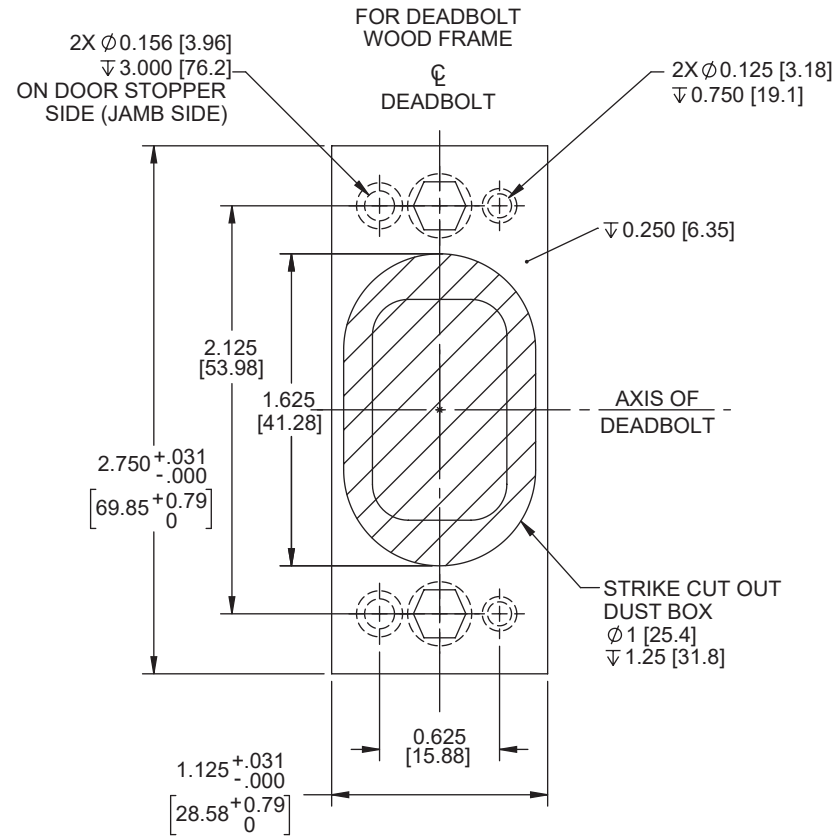

DIMENSIONS = IMPERIAL/IMPÉRIAL (MILLIMETER / MILLIMÈTRE)

3D FILE GOVERNS ALL UNSPECIFIED DIMENSIONS & GENERAL TOLERANCES APPLY / LES DIMENSIONS NON SPÉCIFIÉES SONT DÉFINIES PAR LE FICHIER 3D ET LES TOLÉRANCES GÉNÉRALES S'APPLIQUENT

GENERAL TOLERANCE, UNLESS OTHERWISE SPECIFIED / TOLÉRANCES GÉNÉRALES, SAUF SI SPÉCIFIÉ AUTREMENT

X ± 0.25	THREAD CLASS / FILET	FINISH / FINI
X.X ± 0.25	SAE: 2A-2B	ISO: 6g/6H
X.XX ± 0.25		

HOLE / TROU
 \bar{Q} : +.13/-0.05

ANGLE: ± 1°

CHAMFER / CHANFREIN: \leq ± 5°

AS PER / SELON : ASME Y14.5M-2009

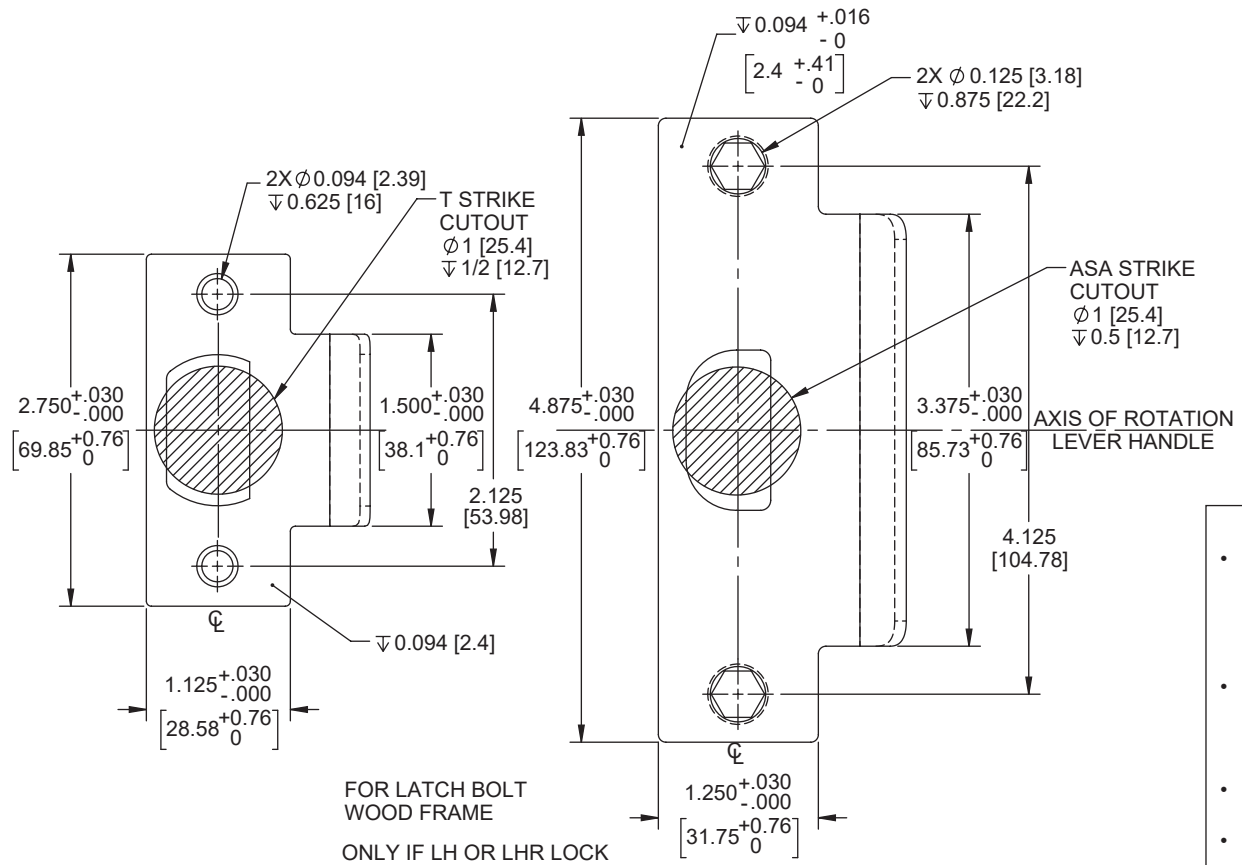

WARNING

- To verify lock coverage and door operation meets expectations, dormakaba strongly recommends completing a full door mockup. This will ensure that all necessary products and parts for a successful installation are included.
- Always validate that you have selected the correct template for specific lock model being installed. The same lock model can be offered with different locking device options.
- Drawing is not to scale. Measurements are for reference only. Not a drilling template.
- If you have any questions, please contact your local sales representative or authorized reseller.

BACKSET ADJUSTMENT FOR 3° BEVEL DOOR

DOOR THICKNESS DIMENSION X	BACKSET ADJUSTMENT DIMENSION Y
1.25 [31.8]	0.032 [0.81]
1.50 [38.1]	0.039 [1.00]
1.75 [44.5]	0.046 [1.17]
2.00 [50.8]	0.052 [1.32]
2.25 [57.2]	0.059 [1.50]
2.50 [63.5]	0.065 [1.65]
2.75 [69.9]	0.072 [1.83]